



Ref. No.	LGETH-140904-054
Issued Date	Sep. 04. 2014
Rev. No.	REV. 0
Rev. Date	-

LG Electronics Inc.

SPECIFICATION SHEET for APPROVAL

MODEL : QP325PBA

CUSTOMER : PHU DAI HUNG

APPROVAL			
NAME			
DATE			
AIR CONDITIONER MODEL			

LG Electronics Inc.

	Designed	Checked	Approved
NAME	<i>Kritsada</i>	<i>Thirak S.</i>	
DATE	<i>04/09/2014</i>	<i>04/09/14</i>	<i>04/09/2014</i>

ORIGINAL
040914

Please read this specification sheet thoroughly before installation or operating.

Please Return 1 Copy on Your Approval.

Air Conditioning Compressor Division LG Electronics Inc.
Tel : (+66)38 - 923 - 109 Fax : (+66)38 - 923 - 119



Ref. No.	LGETH-140904-054
Issued Date	Sep. 04. 2014
Rev. No.	REV. 0
Rev. Date	-

LG Electronics Inc.

SPECIFICATION SHEET for APPROVAL

MODEL : QP325PBA

CUSTOMER : PHU DAI HUNG

APPROVAL			
NAME			
DATE			
AIR CONDITIONER MODEL			

LG Electronics Inc.

	Designed	Checked	Approved
NAME			
DATE			

Please read this specification sheet thoroughly before installation or operating.

Please Return 1 Copy on Your Approval.

Air Conditioning Compressor Division LG Electronics Inc.

Tel : (+66)38 – 923 – 109

Fax : (+66)38 – 923 – 119

Ref. No.	LGETH-140904-054
Issued Date	Sep. 04. 2014
Rev. No.	REV. 0
Rev. Date	-

0.Revision History

Data	Rev. No	Rev. description	Write

Ref. No.	LGETH-140904-054
Issued Date	Sep. 04. 2014
Rev. No.	REV. 0
Rev. Date	-

1.Specification

1.1 Compressor

1	Model Name	QP325PBA
2	Compressor Type	Hermetic Motor Compressor
3	Compression Type	Rotary Type (Rolling Piston Type)
4	Application	Refrigeration system (Cooling & Heating)
5	Refrigerant	R22
6	Safety Approval	-
7	Oil / Oil Charging Amount	NM56 or 4GSI / 700cc
8	Displacement	32.5 cm ³ / rev
9	Painting	Black Color Paint
10	Net Weight (Including Oil, Reference)	22.0 kg
11	Suction Tube I.D	Φ 12.8 mm
12	Discharge Tube I.D	Φ 9.7 mm

1.2 Motor

Motor Type / Starting Type	Single Phase Induction Motor / PSC	
Pole / Rated Output	2 Pole / 1775 Watts	
Power Source	1Ph – 220/240 Volts – 50Hz	
Rated Revolution	2,920 rpm	
Insulation Class	E Class	
Windings Resistance (at 25 °C)	Main	1.30 ± 7% Ohms
	Sub	1.97 ± 7% Ohms
Locked Rotor Ampere	59 A (at 240 V)	

Ref. No.	LGETH-140904-054
Issued Date	Sep. 04. 2014
Rev. No.	REV. 0
Rev. Date	-

1.3 Wiring diagram

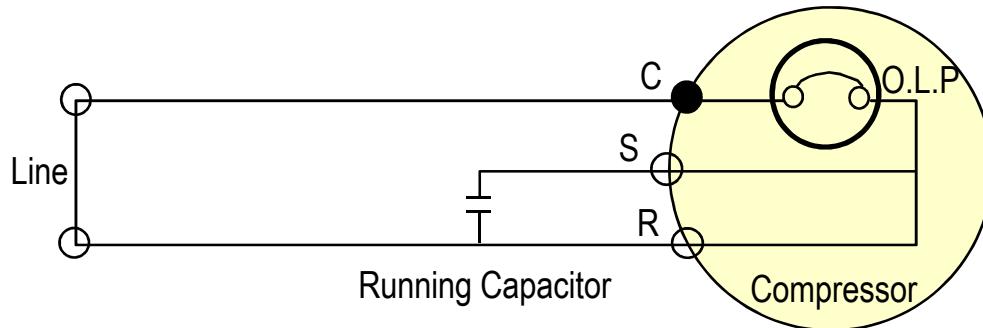

※ Make Sure to connect right way same with the wiring diagram.

1.4 Electrical Component

Running Capacitor	55 MFD / 400 VAC
Over Load Protector	INTERNAL TYPE

1.5 Performance

Voltage		At 220 V	At 240 V
Cooling Capacity (-5% ↑)	[BTU/h]	19,200	19,300
	[W]	5,627	5,656
Power Input (+5% ↓)	[W]	1,778	1,856
EER (-5% ↑)	[BTU/W hr]	10.8	10.4
	[W / W]	3.16	3.04
Running Current (Reference)	[A]	8.8	8.7

☞ Rated Conditions (ASHRAE-T Condition)

Cond. Temp. : 54.4 °C (130 °F)

Evap. Temp. : 7.2 °C (45 °F)

Return Gas Temp. : 35.0 °C (95 °F)

Liquid Temp. : 46.1 °C (115 °F)

Ambient Temp. : 35.0 °C (95 °F)

Ref. No.	LGETH-140904-054
Issued Date	Sep. 04. 2014
Rev. No.	REV. 0
Rev. Date	-

1.6 Noise & Vibration

Voltage		At 240 V
Sound Level	[dB(A)]	68 Max
Vibration	[gal]	2,000 Max

Noise & Vibration Measuring Points

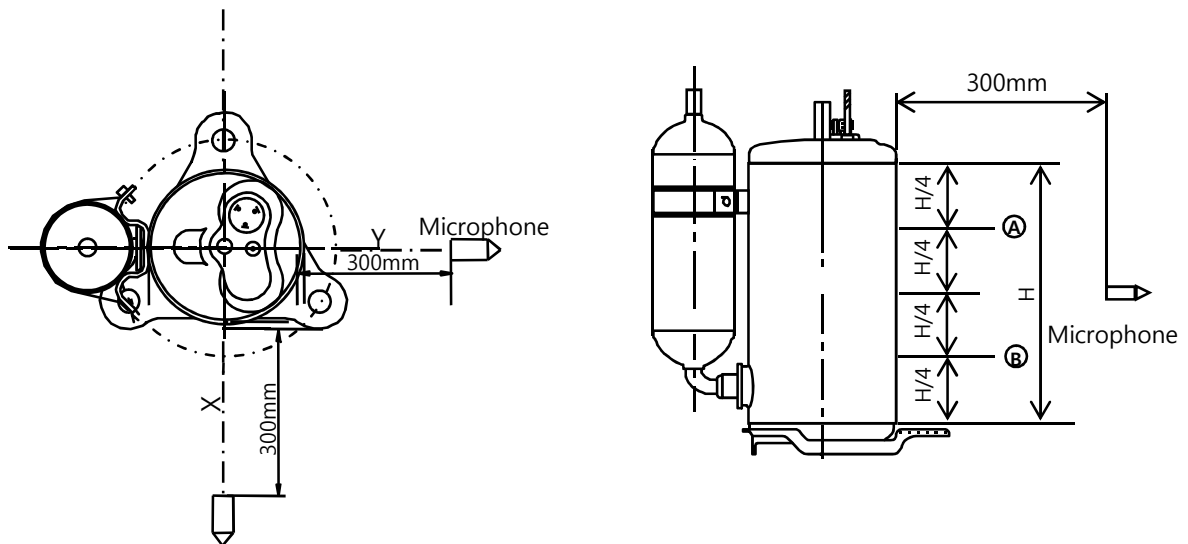

- Measuring points for specification approval
 - Noise : 2 points (X , Y)
 - Vibration : 2 points (A , B)
- Compressor vibration is measured by a vibration meter which is contacted compressor (A) ~ (B) at load condition
- Test Condition :
 - Standard Condition ($P_s/P_d = 5.34 / 20.86 \text{ kg/cm}^2\text{G}$)
 - (Return Gas: 18.3 °C)

Ref. No.	LGETH-140904-054
Issued Date	Sep. 04. 2014
Rev. No.	REV. 0
Rev. Date	-

1.7 Minimum Starting Voltage

Standard Start - Temp. Condition : 35°C - Balanced pressure : Pd – Ps ≤ 0.5 kgf/cm ²	187 Volts Max
---	---------------

1.8 Voltage Range

at Standard Condition	187 ~ 264 Volts
at Overload Condition	198 ~ 264 Volts

☞ Test Conditions

	Standard Condition
Con. Temp (°C)	54.0
Eva. Temp (°C)	7.2
Return Gas. Temp (°C)	35.0
Ambient Temp (°C)	35.0

1.9 Others

Leak Tight Pressure	High Pressure Side	28 kgf / cm ² G
	Low Pressure Side	-
Hydrostatic strength Pressure	High Pressure Side	155 kgf / cm ² G
	Low Pressure Side	50.6 kgf / cm ² G
Insulation Resistance (with 500V D.C Mega Tester)		50 MΩ Min.
Withstand Voltage		At 2,200 V / 1 Sec. Leakage Current is less than 5 mA
Residual Moisture (Karl Fisher Method)		80 mg Max.
* Residual Impurities		70 mg Max

*) Each part was measured separately

Ref. No.	LGETH-140904-054
Issued Date	Sep. 04. 2014
Rev. No.	REV. 0
Rev. Date	-

2.Delivered Parts List

Parts Name	Type (Model)	EA	Parts Dwg. NO.	Supply	
			LG		
Compressor	QP325PBA	1		<input checked="" type="radio"/> Yes	<input type="radio"/> No
OLP	INTERNAL TYPE	1	-	Yes	<input checked="" type="radio"/> No
Cover ,Terminal	-	1	3550U-L005D, (3550U-L005B)	<input checked="" type="radio"/> Yes	<input type="radio"/> No
Gasket	-	1	4986UHL004A, (4986U-L004A)	<input checked="" type="radio"/> Yes	<input type="radio"/> No
Nut, Common	-	1	FAD30241201	<input checked="" type="radio"/> Yes	<input type="radio"/> No
Washer, Customized	-	1	1WPZU-L001A	<input checked="" type="radio"/> Yes	<input type="radio"/> No
Damper, Rubber	-	3	MCQ61847401	<input checked="" type="radio"/> Yes	<input type="radio"/> No
Sleeve, Damper	-	-	-	Yes	<input checked="" type="radio"/> No
Bolt, Stud	-	-	-	Yes	<input checked="" type="radio"/> No
Washer, Plain	-	-	-	Yes	<input checked="" type="radio"/> No
Nut, Hexagon	-	-	-	Yes	<input checked="" type="radio"/> No
Capacitor	-	-	-	YES	<input checked="" type="radio"/> NO
Screw, Earth	M4*0.7 , Length : Max 6mm.	-	-	Yes	<input checked="" type="radio"/> No

※) Refer to Attachments (Accessory Parts Drawings.)

Ref. No.	LGETH-140904-054
Issued Date	Sep. 04. 2014
Rev. No.	REV. 0
Rev. Date	-

3. Operating Limit

3.1 Operation Range

Discharge Pressure	[kgf / cm ² G]	28 Max.
Suction Pressure	[kgf / cm ² G]	2.0 ~ 7.0
Discharge Temp.	[°C]	115 Max.
Motor Coil Temp.	[°C]	130 Max.

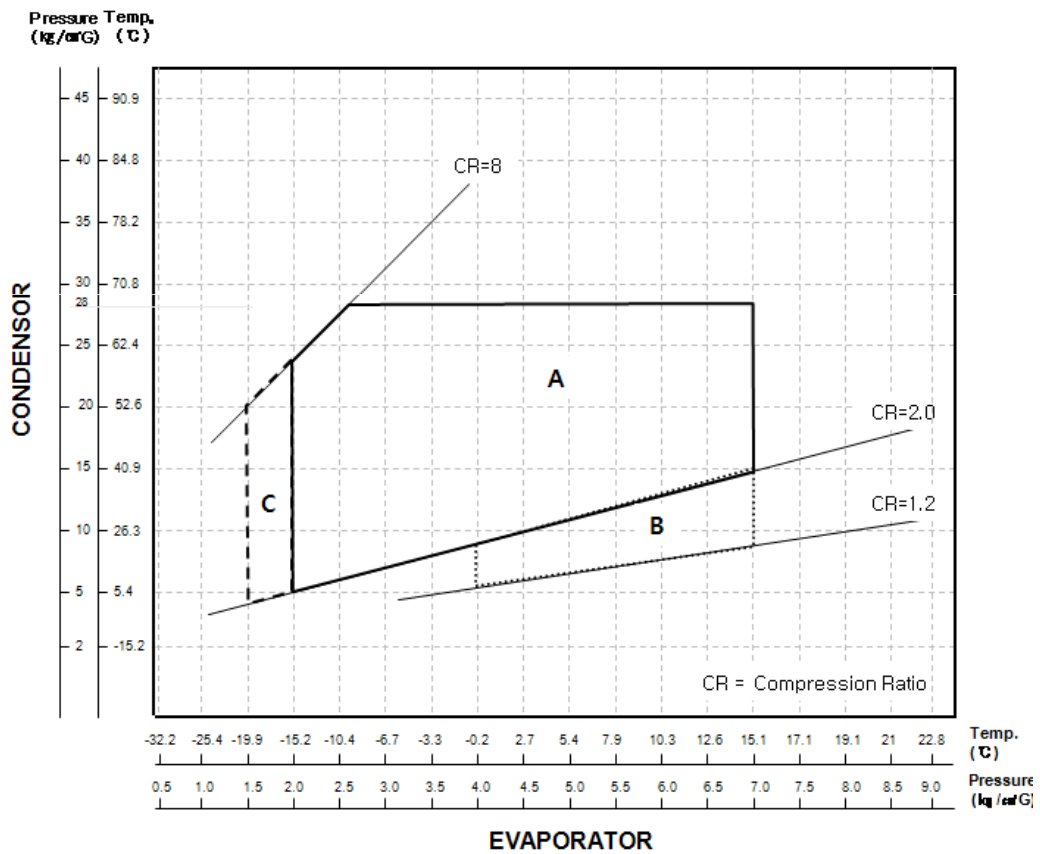

Area A : Normal Operating Zone

Area B : High Density Flow Zone
-During starting within 3 minutes

Area C : Low Pressure Zone(defrosting & re-starting)
-Running time less than 3 minutes.
-Should be checked liquid back

Ref. No.	LGETH-140904-054
Issued Date	Sep. 04. 2014
Rev. No.	REV. 0
Rev. Date	-

※ This guide contains many important safety messages. Always read and obey all safety messages.

▲ WARNING You can be killed or seriously injured if you don't follow instructions.

3.2 Application Limit

Refrigerant Charge Limit	[WRAC for Cooling Only] 2470g Max (*K ≥ 0.3, **OIL Dilution Rate=0.2) [WRAC for Heat Pump] 1850g Max (*K ≥ 0.4, **OIL Dilution Rate=0.22) [SRAC for Cooling Only] 1850g Max (*K ≥ 0.4, **OIL Dilution Rate=0.2) [SRAC for Heat Pump] 1230g Max (*K ≥ 0.6, **OIL Dilution Rate=0.22)
Liquid Refrigerant Back	System should be designed not to allow the liquid to go back to compressor which cause knocking noise , current increase or undesirable vibration and make short compressor life time.
Δ T : Temp. Difference	Δ T = Case Bottom Temp. - Condensing Temp. It must be kept Δ T ≥ 5°C
Pressure Difference in Operating	The Pressure difference in operating shall be 5.0kgf/cm ² or more, but 3 minutes starting excluded.
ON/OFF Operation	Each cycle should be at least 6 minutes (ON Time : at least 3 minute , OFF Time : at least 3 minutes)
Pressure Difference at Starting	When starting, discharge pressure is balanced with suction pressure. (Pd – Ps ≤ 0.5 kgf/cm ²)
Tilt in Operation	The allowable tilt of the compressor in operation shall be 5° or less.
System Accumulator	The Accumulator volume should be enough to cover 50% of maximum system refrigerant volume. Ratio coefficient 'K' should be over 0.6(heating system) or 0.4(cooling system) $K = \frac{\text{Volume of Accum. (Comp+System)} \times \text{Specific gravity of Refrigerant}}{\text{Charged Weight of Refrigerant}}$ ※ Effective volume of compressor accumulator = 594 cm ³ ※ Specific gravity of refrigerant (R22) = 1.25 g/cm ³ (at 20°C) If coefficient "K" does not meet recommendation, refrigerant system must check liquid back phenomenon at accumulator.
Protecting Reverse Operation	The compressor must be operated by proper voltage in accordance with the frequency without reverse revolution condition. The reverse revolution condition can be avoided by just keeping right order of phase supplied power source.

Ref. No.	LGETH-140904-054
Issued Date	Sep. 04. 2014
Rev. No.	REV. 0
Rev. Date	-

▲ WARNING

3.2 Application Limit

Frequency Range	Rated Frequency $\pm 2\%$
Pipe Stress	Don't allow any force on discharge & suction pipe . The piping stress must be less than 300kgf/cm ² at starting and stopping. And less than 153kgf/cm ² at running.
Oil Level	It must be checked oil level by the compressor with sight glass we supply. And oil level must be kept over guide line level **note 2. at any condition.
Protection device for BLDC	Refrigeration system must has the compressor protection device like over pressure, high temperature, sensing locked pump in the controller. When starting & running fail by abnormal overload, controller must be able to cut off power of compressor before motor burn out.
	An earth terminal should be installed to prevent electrical accidents.
Pump down refrigerant	If pump down time is too long, compressor can be damaged due to excessive temperature increase or poor lubrication. Guideline of pump down process. - Time : less than 30 seconds - Suction Pressure : It should not run under below 1kgf/cm ² G. And before closing a service valve, compressor running for more than 5 minutes is recommended.

※ If gas charge amount of refrigerant specified is exceeded, both parties should discuss the matter to determine compressor specification. (accumulator volume, lubricating oil amount) and system specifications (crank case heater, oil separator , additional accumulator, etc)

Ref. No.	LGETH-140904-054
Issued Date	Sep. 04. 2014
Rev. No.	REV. 0
Rev. Date	-

▲ WARNING

3.3 Process Limit

Use defined Refrigerant and oil	Any process in where the HCFC's refrigerant or the different kind of oil against the defined. Compressor oil are mixed should be avoided.
Avoid Damage running	The running operation that inspection and the protector inspection that affect a damage to the function and durability of the compressor should be avoided
Running dummy indoor	When the outdoor unit is operated with the indoor dummy unit, the discharged oil should be recovered enough
Prevent oxidation in pipe	Always purge the system and the compressor with the dry nitrogen in order to prevent oxidation of the piping
Charging Refrigerant	When charging refrigerant into the cycle, make sure that refrigerant always be filled from the higher pressure side (condenser exit) of the cycle. If liquid refrigerant is sucked in to the compressor liquid compression occurs, The discharge valve is damaged, lubrication effectiveness degenerates and reliability drops noticeably
Avoid Vacuum running	Do not operate the compressor in a vacuum state. Furthermore do not apply high voltage to a vacuum state compressor. There is a danger that insulation could degenerate, causing electric shock
Avoid Air compression	Do not compress the air including the case of leakage in the refrigeration cycle. If compressors run with air mixed, inside the compressor is heated and pressurized , which may cause an explosion
Promptly Assemble compressor in line	After removing rubber plugs from compressor tubes, Promptly use the compressor. And do not leave in the atmosphere for 10 minutes over. If Air gets into the compressor , accelerating degeneration of the inside of the cycle or compressor
Wiring	Wires connected to the compressor, follow the compressor specification manual and instructions
Storage temperature	-10°C ~ 65°C

Ref. No.	LGETH-140904-054
Issued Date	Sep. 04. 2014
Rev. No.	REV. 0
Rev. Date	-

*** Note 1. OIL Dilution rate**

$$\frac{\text{Oil Weight}}{\text{Refrigerant Weight} + \text{Oil Weight}} \geq 0.22(\text{Heating}) \text{ or } 0.20(\text{Cooling})$$

※ Specific Gravity of NM56(4GSI) = 0.92 (at 20°C)

[Unit]

☞ Oil Weight : [g]

☞ Refrigerant Weight : [g]

**** Note 2. Oil Level Guide Line**

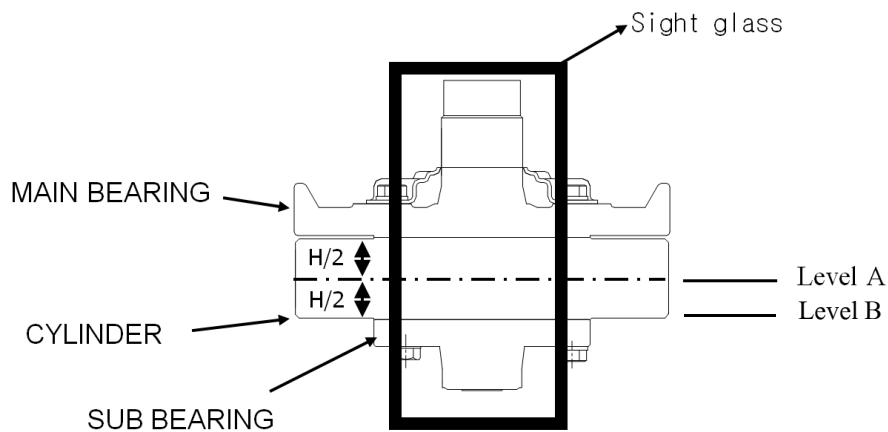

Over Level A : Steady state at any condition.

Over Level B : Minimum level of transition period within 3minutes

Ref. No.	LGETH-140904-054
Issued Date	Sep. 04. 2014
Rev. No.	REV. 0
Rev. Date	-

*** LABEL ***



All safety messages will identify the hazard, tell you how to reduce the chance of injury, and tell you what can happen if the instructions are not followed. You are strongly advised to follow these safety instructions.



This is the Safety alert symbol. It indicates a hazardous situation which, if not avoided, could result in death or serious injury.



This is the Electric shock hazard symbol. It indicates a hazardous situation which, if not avoided, could result in the electric shock.



This is the Getting burnt symbol. It indicates a hazardous situation which, if not avoided, could cause fire.



This is the Explosion or Fire symbol. . It indicates a hazardous situation which, if not avoided, could cause explosion or fire.

***1. Effective Period of This Document ***

This document will be effective after LG's receipt with your authorized signature. When design modification is approved by the customer , the current document is unavailable.

***2. Compressor operating range ***

The Compressor can operate within the limits of the outlined area. Outside these operating fields, the system cause early defects in the compressor. The compressor defects caused by applications operating outside the outlined area will not be considered under the warranty. If the appliance be operated out of the operating range, it must be agreed with the supplier.

Attachment

PAGE

1. Compressor Drawing : A-1
2. Accessory Fitting : A-2
3. Part Drawings : A-3 ~ A-7

Ref. No.	LGETH-140904-054
Issued Date	Sep. 04. 2014
Rev. No.	REV. 0
Rev. Date	-

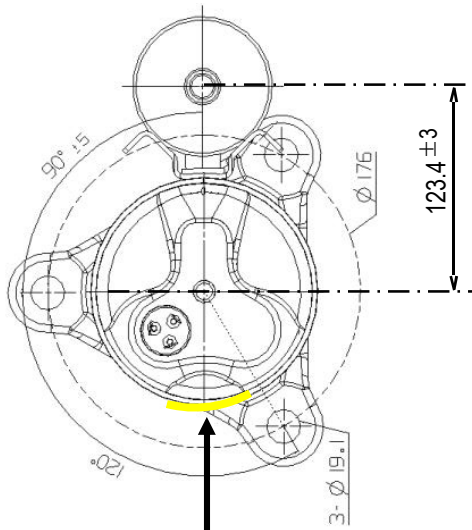

Label position

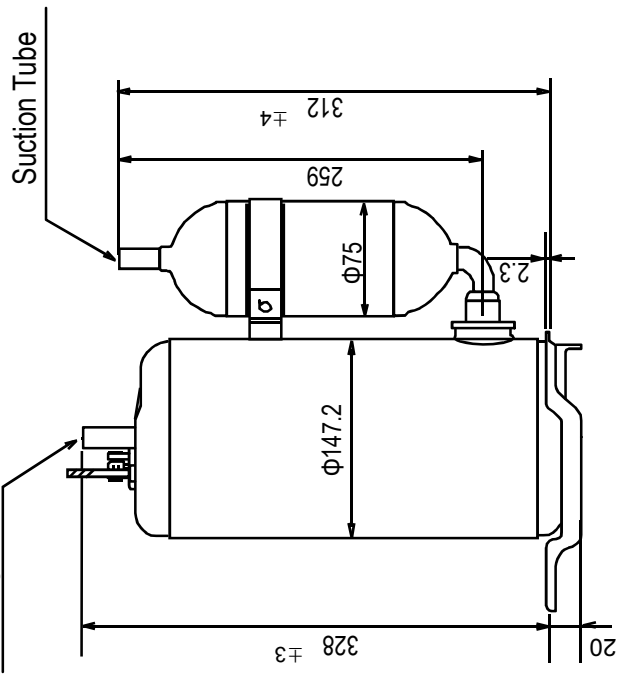
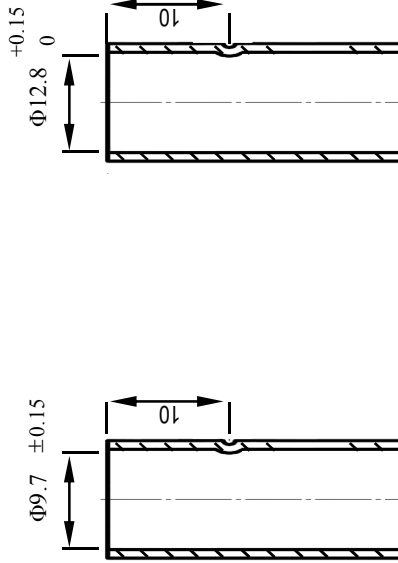

Detail for Discharge tube Detail for Suction tube

- NOTES
1. PAINTING : BLACK PAINT (ELECTRO DEPOSITION)
 2. OIL : NM56 OR 4GSI 700cc CHARGED
 3. NITROGEN CHARGED AFTER DEHYDRATION

UNIT	mm	SCALE	N / S
DES. ENGR.		CHF. ENGR.	
Sep. 04. 2014		Sep. 04. 2014	
KRITSADA S.		APIPOL K.	
LG Electronics Inc.		CUSTOMER	
EC Business Unit		PHU DAI HUNG	
COMP. OUT LINE			
QP325PBA			

Accessory Fitting

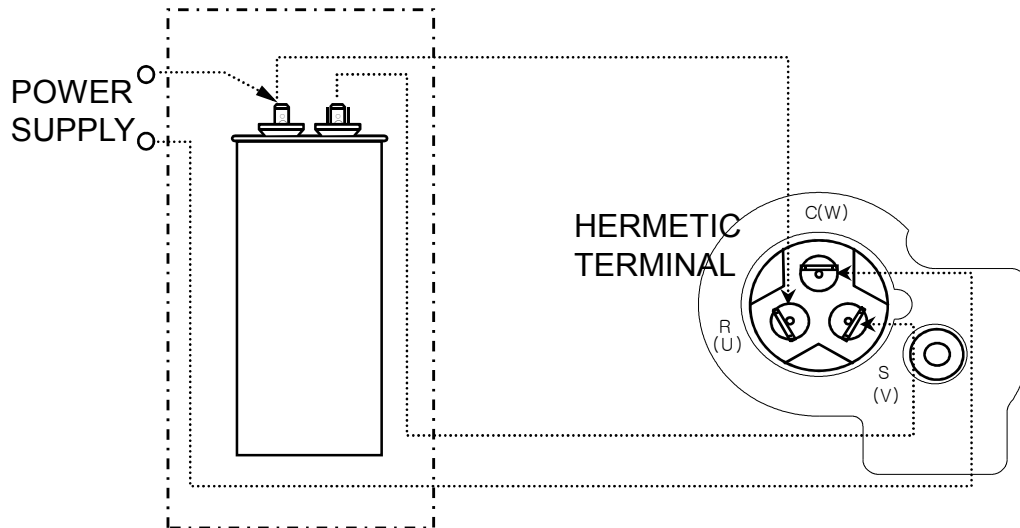

RUNNING
CAPACITOR

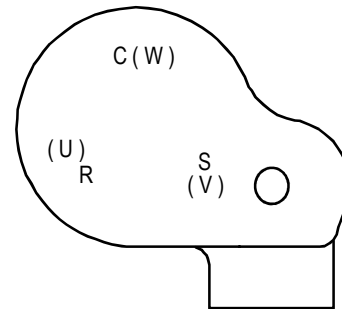

Cover Terminal

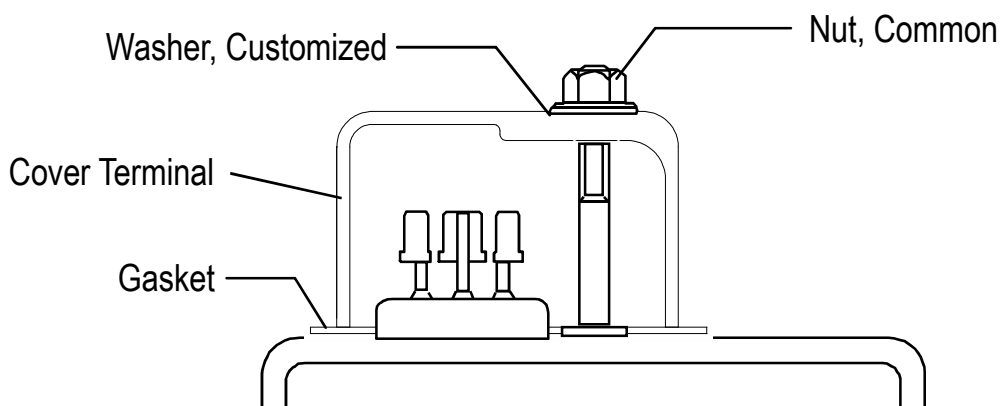

C,S,R mark embossed on cover terminal
Nut assembly torque should be below 20 kgfcm.

Cover, Terminal

Drawing No. 3550U-L005D , (3550U-L005B)

(UNIT : mm)

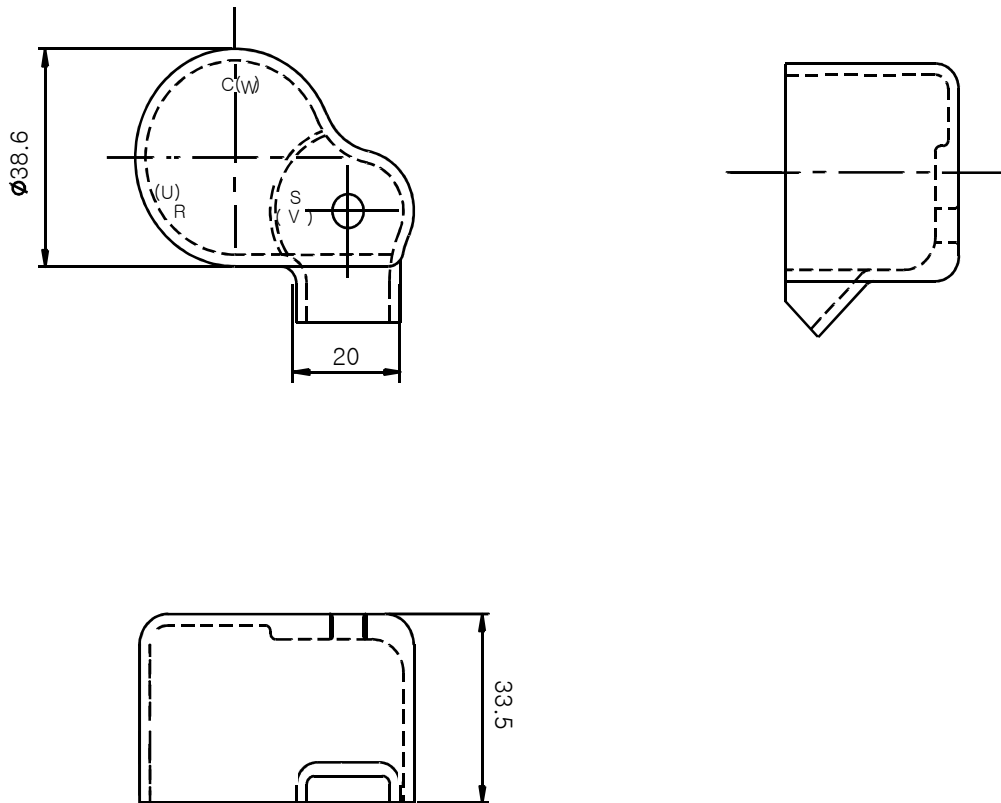

MATERIAL	COLOR	REMARK
Lupox TE-5006F (polybutylene terephthalate)	BLACK	MARKS(C(W),R(U),S(V))

LG Electronics

Gasket

Drawing No. 4986UHL004A , (4986U-L004A)

(UNIT : mm)

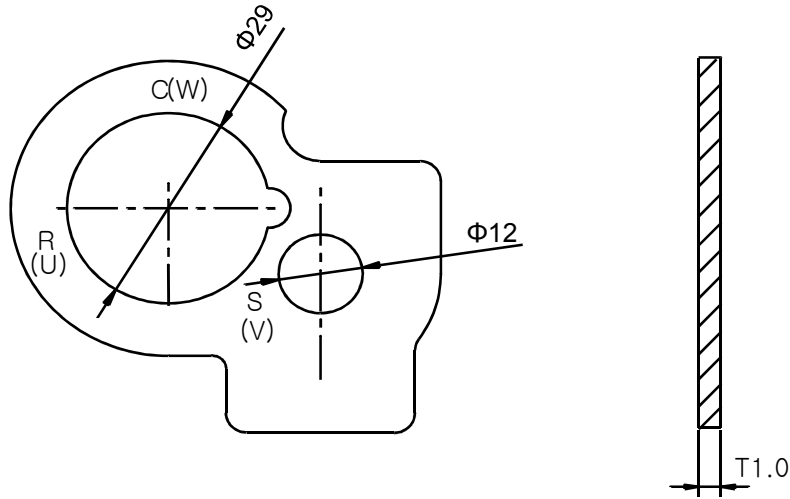

MATERIAL	REMARK
SILICONE	MARKS(C(W),R(U),S(V))

LG Electronics

Nut, Common

Drawing No. FAD30241201

(UNIT : mm)

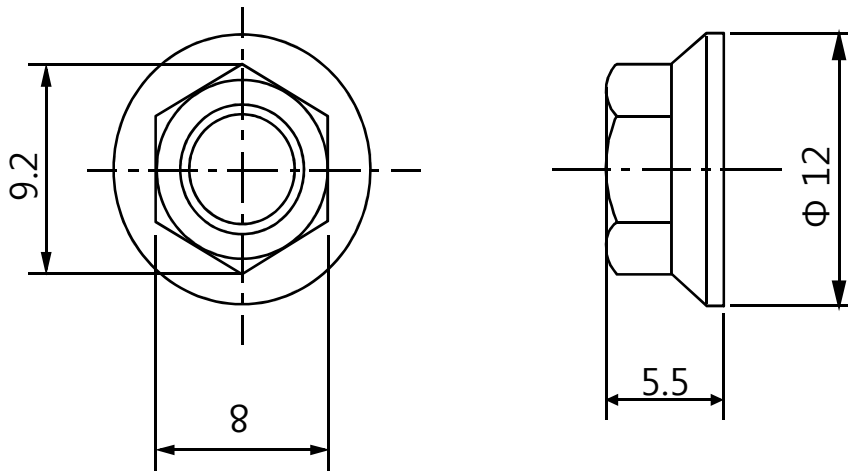

* MATERIAL : STEEL (ELECTRIC PLATING OF ZINC)

Washer, Customized

Drawing No. 1WPZU-L001A

(UNIT : mm)

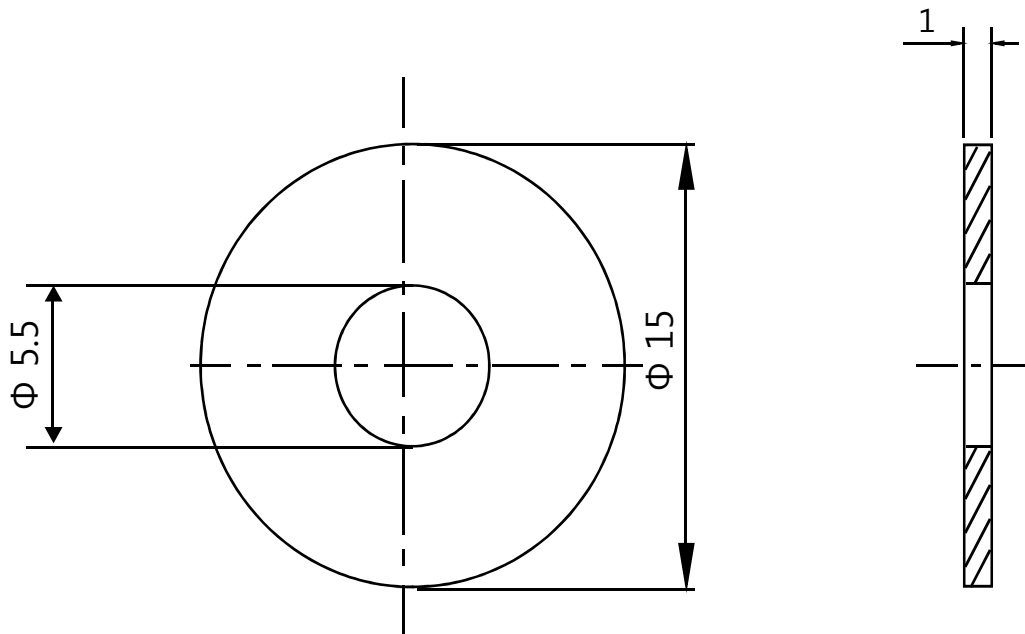

* MATERIAL : POLYAMIDE (NYLON)

LG Electronics

Damper, Rubber

Drawing NO. MCQ61847401

(UNIT : mm)

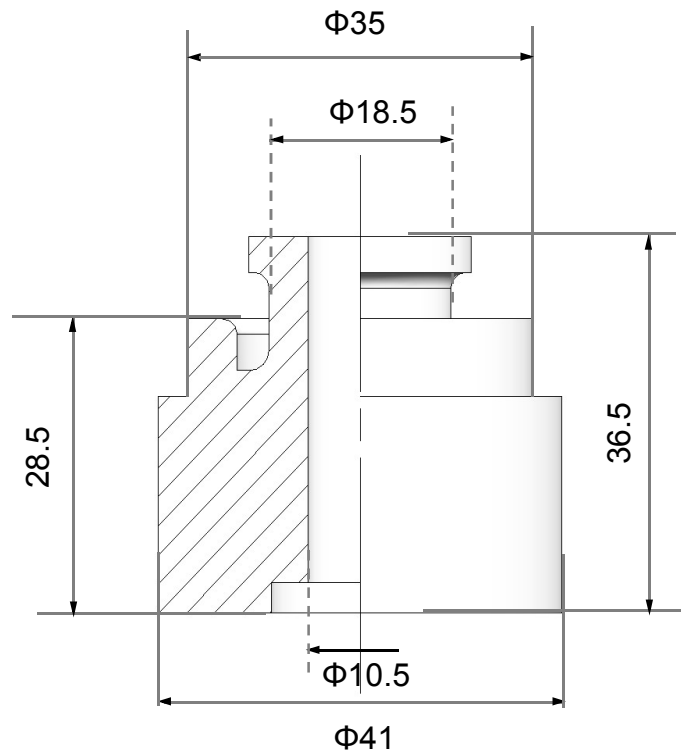

* MATERIAL : NATURAL RUBBER